

SGT-P

휴대용 단일가스 검지기(센서 교체 타입)

SENKO



GAS TYPE

O₂ CO H₂S H₂ SO₂ NH₃ NO₂

Description

SGT-P는 배터리 및 센서 교체 type 의 휴대용 단일가스검지기로서, 산소결핍이나 유독가스로부터 근로자를 보호하기 위해 가스를 실시간 측정해 농도를 표시하고 위험 발생 시 경보를 발생합니다.

Key Feature

- 센서 및 배터리 교체 type
- 전원 on/off 가능
- IR Link 를 통한 손쉬운 환경설정 및 데이터 관리
- Docking Station 을 통한 간편한 검교정
- 우수한 방수/방진 구조
- Event log 30개

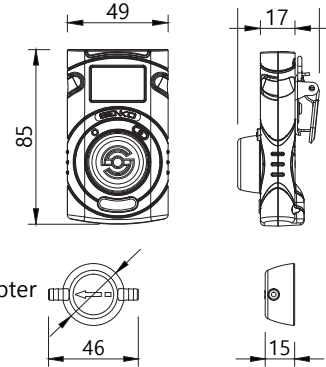

Specification

Model	SGT-P
Sensor Type	Electrochemical
Measurement	Diffusion type
Display	LCD display
Audible	90dB at 10cm
Warning Lamp	Red Flashing LEDs (Light-Emitting Diode)
Vibration	Vibration Alarm
Battery	Manufacture: Vitzrocell / P/N: SB-AA02(P) / System: Lithium Primary Battery Nominal voltage: 3.6V / Nominal capacity: 1.2Ah
Temperature & Humidity	-40°C ~ +50°C(for Toxic) / -35°C ~ +50°C(for O ₂) 5% ~ 95% RH (non-condensing)
Case	Rubber Enclosure
Accessories	Calibration Cap, Manual, Test Report
Option	External Sampling Pump (SP-Pump101), SENKO-IR Link, Docking Station
Size & Weight	Size: 54mm(W) x 91mm(H) x 32mm(D) Weight: 93g(Toxic), 104g(O ₂) (Battery, clip included)
Event Log	Recent 30 alarms
Approval	ATEX II 1 G Ex ia IIC T4 Ga IECEX Ex ia IIC T4 Ga KTL Ex ia IIC T4 Ga / IP67

Accessories

IR-Link

IR-Link 를 통해 알람값 설정, 펌웨어 업데이트, 이벤트 로그 다운로드 및 보정 등을 수행할 수 있습니다.



Sampling pump (SP-Pump101)



Extension Probe 5M/ 10M



SGT Docking Station



Sensor specification

Gas	Measuring range	Low Alarm	High Alarm
O ₂	0~30%Vol	19%Vol	23%Vol
CO	0~500ppm	30ppm	60ppm
H ₂ S	0~100ppm	10ppm	15ppm
H ₂	0~1000ppm	100ppm	500ppm
SO ₂	0~50ppm	2ppm	5ppm
NH ₃	0~100ppm	25ppm	35ppm
NO ₂	0~20ppm	3ppm	5ppm