



GAS TYPE

O₂ CO H₂S CH₄

Description

MGT 는 4가지 주요 가스를 동시 측정하는 휴대용 복합가스검지기로서, 산소결핍, 독성가스 중독 및 가스폭발로부터 근로자를 보호하기 위해 O₂, CO, H₂S, 가연성가스(CH₄)를 실시간 측정해 농도를 표시하고 정보 설정 값에 도달 시 경보를 발생합니다.

Key Feature

- 4가지 가스 동시측정
- 충전형 배터리(완충 소요시간: 6시간)
- 완충 시 25시간 연속 사용 가능(MGT-P)
- 완충 시 60일 연속 사용 가능(MGT-N)
- IR Link 를 통한 손쉬운 환경설정 및 데이터 관리
- Docking Station 을 통한 간편한 검교정
- 우수한 방수/방진 구조

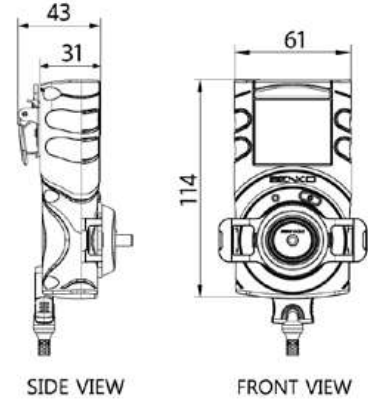

Specification

Model	MGT
Self-test	Full function self-test upon activation Sensors, battery and circuitry - continuous
Detecting Method	Diffusion
Display	LCD Display (back-light)
Alarm	LED flashing, Sound, Vibration
Sensor	O ₂ , CO and H ₂ S: Electrochemical Combustible(LEL): IR or Pellistor
IP	67
Temperature	-20°C ~ +50°C
Humidity	5~95% RH(Non-condensing)
Batteryw	Rechargeable Li-ion power supply unit (2000mAh)
Charge Time	4-6 hours
Battery Life	IR: 60 days continuous / Pellistor: 25 hours continuous
Low Battery Alarm	20 minutes / 10 minutes / 5 minutes expired: 5 long beeps/flashes and then Off is displayed
Weight	240g
Size	61(w) × 114(h) × 43(d)mm
Optional Accessory	MGT-IR Link, Docking Station, SP-Pump 101
Approval	ATEX II 1 G Ex ia IIC T4 Ga CSA Class 1, Zone 0, ex ia IIC T4 Ga IECEX Ex ia IIC T4 Ga KTL Ex d ia IIC T4 / IP67

Accessories

IR-Link

IR-Link 를 통해 알람값 설정, 펌웨어 업데이트, 이벤트 로그 다운로드 및 보정 등을 수행할 수 있습니다.

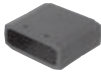

Vehicle power adaptor



Sampling pump (SP-Pump101)



Extension Probe 5M/ 10M



SGT Docking Station



Sensor specification

GAS	Measuring range	Low Alarm	High Alarm
O ₂	0~30%Vol	19%Vol	23%Vol
CO	0~500ppm	30ppm	60ppm
H ₂ S	0~100ppm	10ppm	30ppm
CH ₄	0~100%LEL	10%LEL	30%LEL